

Coaxial Probe Requirements:

Complete the following questions to streamline the process of building a strapping chart in the Titan Logix SensorLink software for a Coaxial Probe. Note, this form only applies for TD100 transmitters.

1. What units do you want to use for measuring the depth inside your compartments?

- Inches
- Centimeters
- Millimeters

2. How do you want your volume to appear on the FINCH II Display?

Note: Your volume displayed on the FINCH II Display is your gross volume per compartment. This value is also not temperature corrected.

- Cubic Meters
- Cubic Yards
- Barrels
- Cubic Feet
- Imperial Gallons
- US Gallons
- Liters

3. How many digits after the decimal place do you want to have appear on the FINCH II Display?

Note: TD100 transmitter supports up to 5 digits (e.g., 13.424, 210.32, 3100.1, 16745)

Total Offset Measurements

4. What is the distance from the bottom of the probe nut to the top of your tank? This is the Probe Offset value.

5. What is your tank shell thickness?

Your Total Offset Default Value for Coaxial Probes in SensorLink: **1.5"**

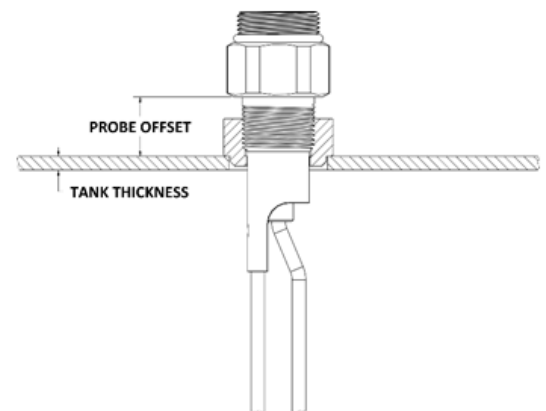

**Total Offset =
Tank Thickness + Probe Offset**

Alarm Set Points

6. What is your load capacity per compartment?

7. 2Lo Reading: When do you want to have your FINCH II Display start showing your volume amount? It will show 2Lo before reaching this setting.

- Performance Mode:** 4.5" up the probe from the bottom of the tank
- Standard Mode:** 5.5" up the probe from the bottom of the tank

8. FILL Alarm: Do you want to set a Fill Alarm?

Note: This is set from the FINCH Display

- Yes
- No

If yes, where do you want to set this alarm at?

9. HH Alarm: Where do you want the High-High (HH) level alarm to be?

The maximum level for this is 2 inches below the Spill level. Most people use this maximum for their HH level.

10. SPILL Alarm: Where would you like to set the Spill alarm? It is adjustable from 4" to 17" below the probe nut.

